

Utilizing an Aluminum Oxide Sensor 600 Times More Sensitive than Conventional Sensors

TELEDYNE ANALYTICAL INSTRUMENTS



8800B Wall Mount

8800P Portable

8800A Panel Mount

8800T Transmitter

8800 SERIES

Trace Moisture Analysis Instrumentation

Accurate detection of trace levels of moisture has been a challenge to the process world owing to the fact that high concentrations of water are present in the atmosphere; approximately 1% by volume in room air.

Teledyne Analytical Instruments is well aware of this challenge, having successfully developed one of the broadest lines of trace ppb/ppm O₂ analyzers commercially available. In developing our trace O₂ line, we have had to contend with the fact that 209,000 ppm of O₂ is present in the atmosphere – ready to jeopardize the analysis of typically less than 1 ppm of O₂. Teledyne is utilizing 50 years of expertise in detecting trace oxygen to produce a complimentary line of trace moisture analyzers – Series 8800.

THE HEART OF THE PRODUCT – HYPER THIN FILM (HTF) SENSING TECHNOLOGY

The 8800 series uses field proven aluminum oxide (Al₂O₃) sensing technology to accurately detect trace moisture on either a continuous or spot checking basis. All Al₂O₃ sensors share the same basic operating principle: the capacitance measured between the sensor's aluminum core and gold film deposited on the oxide layer varies with the water content.

The Series 8800 moisture sensor employs unique Hyper Thin Film (HTF) technology, which offers three major structural improvements in Al₂O₃ sensor design. These structural changes, noted below, provide the user with increased sensitivity, greater stability, and a quicker response time when compared to other conventional aluminum oxide sensors on the market today.

HYPER THIN FILM LAYER

The thinner oxide layer of the HTF sensor results in higher capacitance changes (stronger signal generated than conventional sensors) because capacitance is inversely proportional to the distance of the capacitors' plates from each other (the distance between the aluminum core and the gold film deposited on the oxide layer). The thinner layer also means water molecules will travel faster in and out of the sensor pores, therefore responding several times faster than conventional sensors.

BARRIER LAYER

In HTF sensors, the transition between the aluminum oxide and the aluminum core is sharp and clearly defined. This inner barrier layer produces a capacitor with its electrodes very close together, which in turn leads to the sensor's high wet to dry capacitance ratio. The benefit of the high wet to dry capacitance ratio is that drift in capacitance, due to undesirable factors, is much less significant.

This is clearly a benefit when comparing HTF versus conventional sensors where temperature sensitivity and aging drift are concerned. An added benefit associated with this sharp transition in the barrier layer is a reduction in metal migration, one of the major causes of aging drift in conventional sensors.

PORE GEOMETRY

The most significant difference between HTF and conventional sensors is their pore geometry. While conventional sensors rely on hygroscopic Al₂O₃ structures to attract water, HTF sensors instead rely on a pore geometry that slows the Brownian motion of the water molecules entering the pores.

The HTF sensor design results in more dielectric in the pores and consequently a higher capacitance. An added benefit is derived from the fact that HTF pore geometry does not significantly change over time. Conventional Al₂O₃ structures, however, are not stable and collapse slowly into non-hygroscopic structures. As a result, conventional sensors are subject to higher drift rates and require frequent re-calibration.

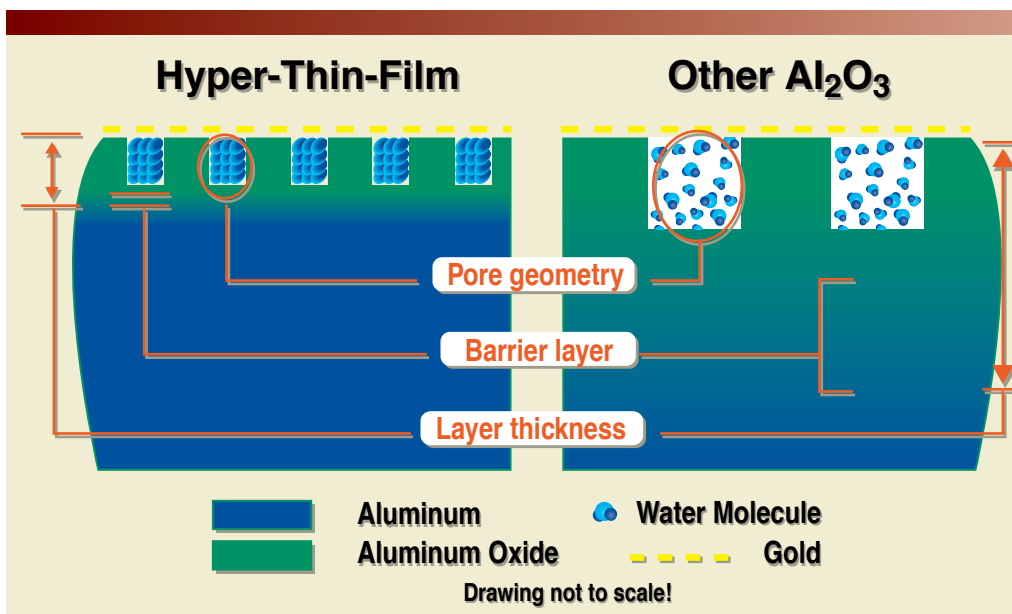

NOTE: It is equally important to note that HTF Al₂O₃ high capacitance sensors are manufactured with high uniformity allowing sensors to be freely interchanged in the field without factory re-calibration or changing of EPROMS, as required with conventional Al₂O₃ sensors.

Graphic representation of HTF vs. Other Al₂O₃ sensors

**HTF™ vs. Conventional Al₂O₃ Sensor
Change of Capacitance with Dewpoint**

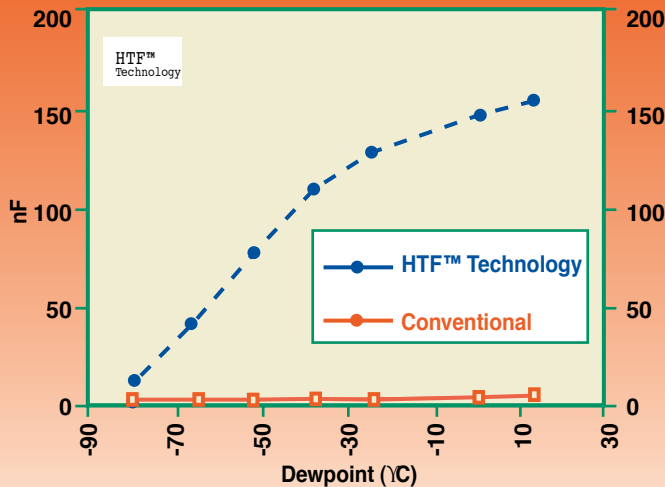

**HTF™ vs. Conventional Al₂O₃ Sensor
Comparison of curve shape**

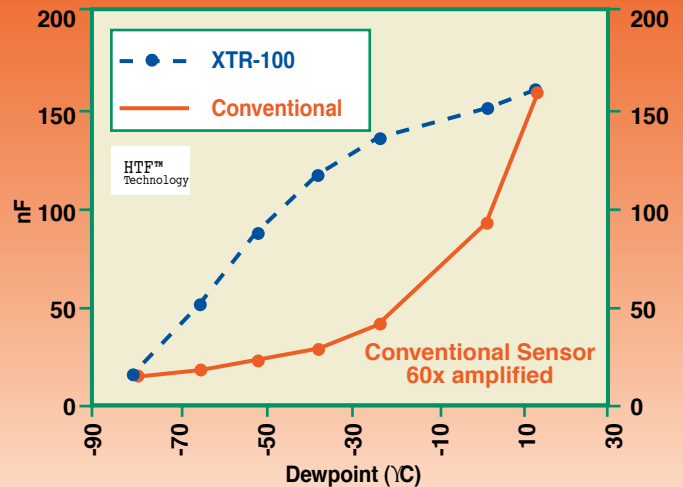

The change of capacitance with moisture of HTF sensors over the full measurement range is 60 times larger than that of conventional sensors. However, because of the improved linearity of HTF sensors at the low end, capacitance changes with moisture are about 600 times larger than that of conventional sensors. The larger sensitivity makes HTF sensors more stable and resistive to other influences such as temperature, electrical noise, and long term drift.

VERSATILE DESIGN OPTIONS

The Series 8800 Single Point Trace Moisture Analyzers are provided in four compact, reliable designs with the ability to detect moisture from -100°C to ambient dewpoint levels of +20°C on either a continuous or spot checking basis.

- 8800A – Flush Mount DIN enclosure with connections made via a pluggable screw terminal block
- 8800B – Wall Mount N4X (IP65) enclosure with connections made 3 bottom watertight fittings
- 8800P – Portable battery operated design available in the Standard Version, I/O Version, and I/S Version (I/S version suitable for hazardous areas)
- 8800T – Low-cost, loop powered 4-20mA transmitter design with built-in LCD display

COMMON ELECTRONICS PLATFORM

The Series 8800 electronics feature a custom LCD 3.5 digit display with backlight capabilities (backlight not available on 8800T). Each controller is operated through a menu-driven user interface. The push buttons or keys have a tactile feel, and to provide additional feedback to the user they also produce a beep when depressed.

Each unit uses a state of the art microprocessor offering advanced intelligent features. In general, the MODE button navigates through the different user options; the UP and DOWN buttons modify the units, values, or choices in the selected mode; and the Pressure Correct button is used to either abort out of a mode or to activate the pressure correction function of the instrument.

The user can select the moisture analysis readout to be displayed as Deg C, Deg F, ppm and for natural gas applications in lbs of H₂O/ million cft or g/m³.

Most versions offer the common options of two adjustable alarms, an isolated 0-24mA or 4-20mA output or RS-232C serial interface. The instrument also has an indication for sensor open, short or electronic system failure to quickly alert the operator to a possible malfunction situation. In addition, most versions offer extensive self-diagnostic features that are performed at both start-up as well as once every two minutes.

PRESSURE CORRECTION FUNCTION

The moisture readings are typically displayed at sensor pressure (atmospheric). Alternatively, the operator can display the readings at the line pressure by selecting and setting the Pressure Correct Mode key. Readings are typically read on a dewpoint basis in Deg C or Deg F. For readout on a ppm basis, the operator must control / know the line pressure and program this value into the controller via the pressure correct function.

Teledyne's XTR-100 sensor.



8800A

FRONT VIEW

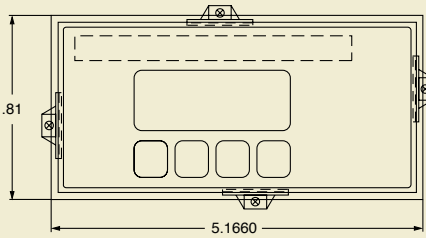

SIDE VIEW

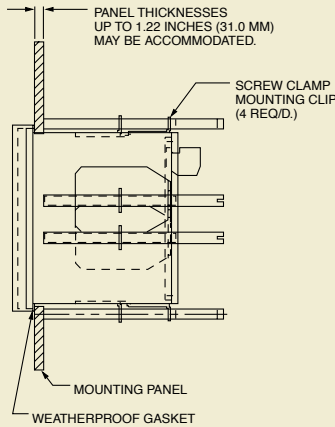

POSSIBLE FIELD MOUNTING CONFIGURATIONS

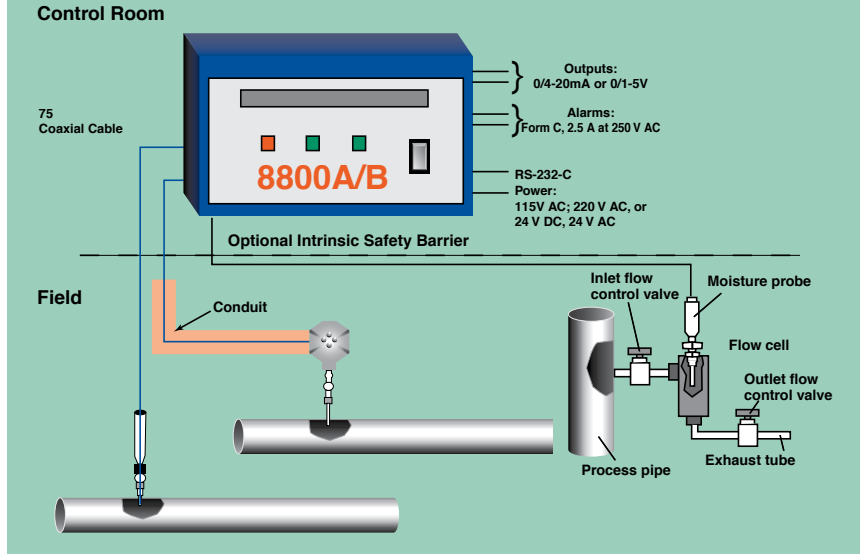

SENSOR INSTALLATION CONSIDERATIONS

Proper sample handling is crucial to maintaining the tight moisture control demanded by the industry today. Operators can assist in achieving a successful dew point measurement by

- Mounting the sensor as close to the measurement point as possible
- Mounting the instrument as close to the measurement point as practical

Leakage, pressure / temperature gradients, and moisture absorption / desorption characteristics also need to be taken into careful consideration when designing the appropriate sample system for dew point analysis. Material absorption / desorption affects overall system response. For low dew point analysis applications, stainless steel wetted parts must be employed to reduce severe lag times typically associated with more hygroscopic materials. Ideally a minimum number of joints / fittings and other plumbing upstream of the Al₂O₃ sensor should be maintained to reduce the number of locations where moisture could collect or a leak could form.

Temperature Effect on XTR-100 Dewpoint Reading

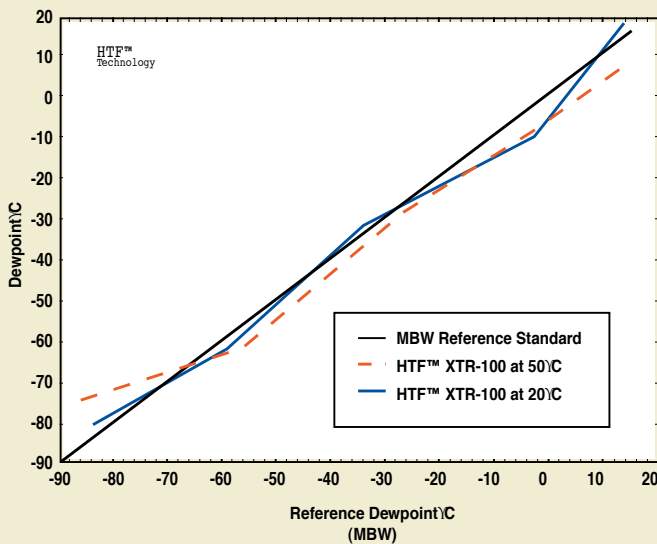

Temperature Effect on Conventional and Ceramic Al₂O₃ Dewpoint Readings

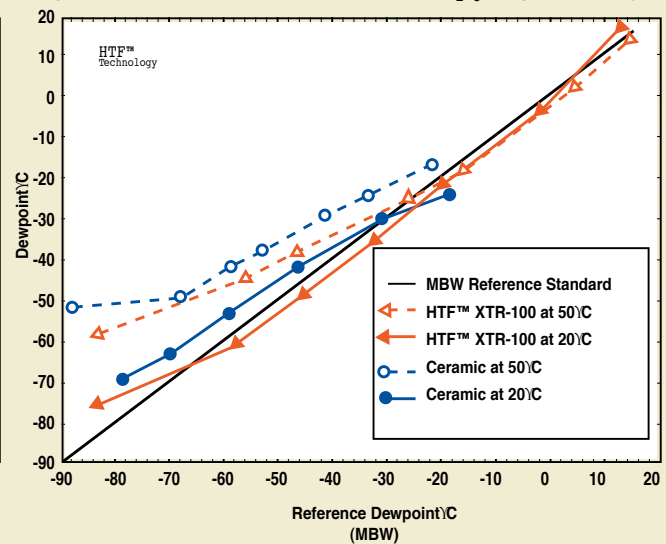

HTF aluminum oxide sensors offer excellent temperature stability over their full analysis range. Only below -70°C (dp) does the measurement become slightly temperature sensitive. Temperature coefficients remain small enough, however, to allow for software compensation. The temperature coefficients of conventional and ceramic sensors relative to their sensitivity to moisture are too large to allow for an accurate compensation through software.

8800B

8800T

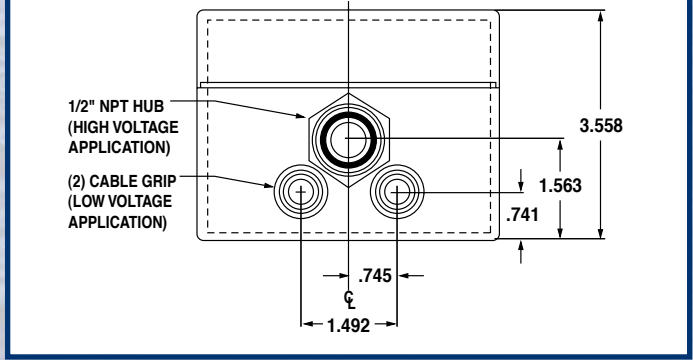
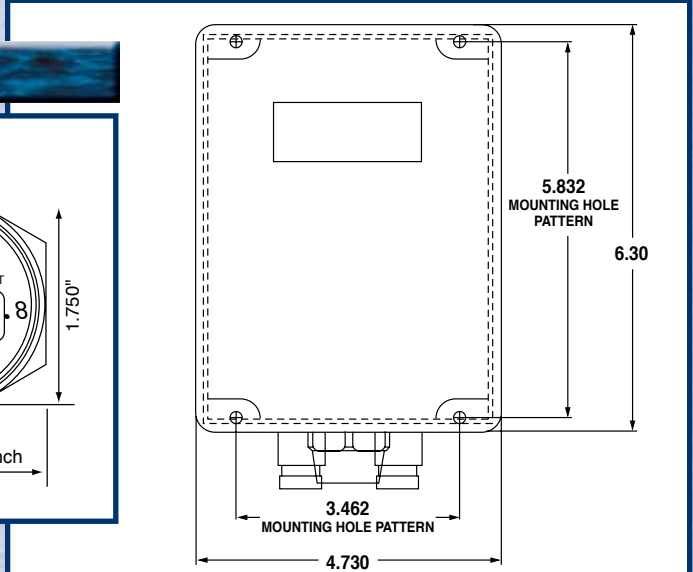
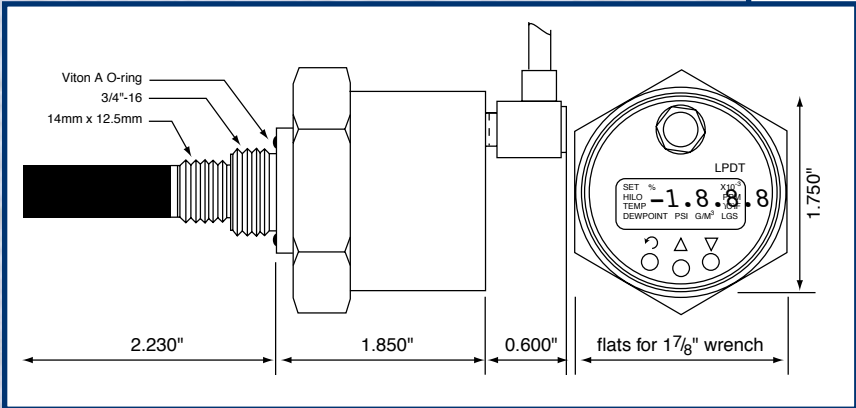

Operating Principle - Model 8800P

Aluminum oxide sensors absorb water molecules much faster than desorb. It is therefore an advantage if, at the beginning of a measurement, the sensor is dryer than the sample to be measured.

The 8800P accomplishes this by keeping the sensor in dry storage until the measurement is taken. The sensor slides directly from dry storage into the sample cell without coming in contact with ambient air. After the measurement is complete, the sensor returns to storage where it is dried down for the next sample.

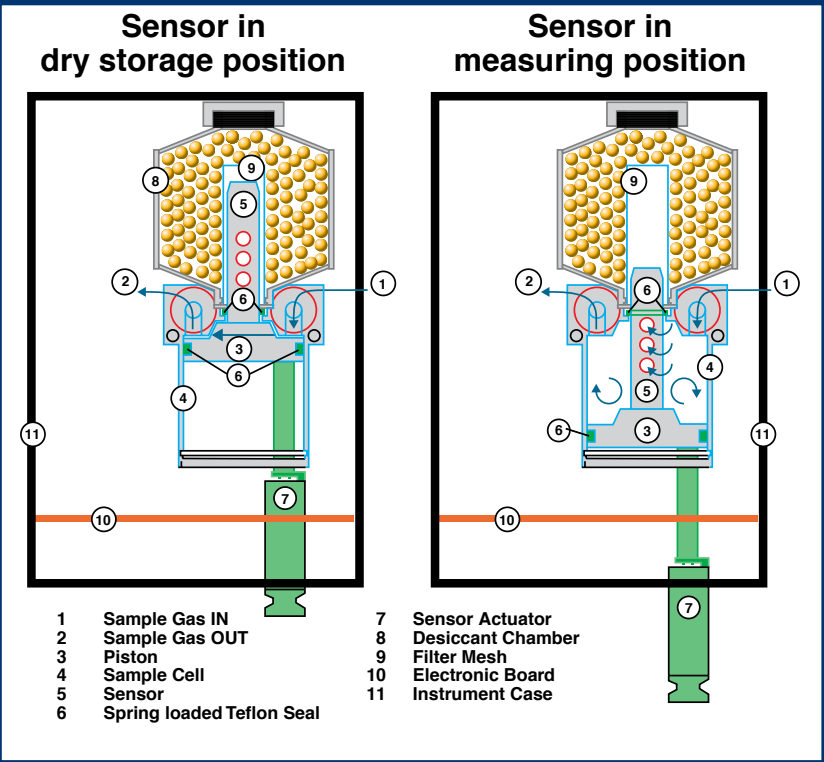

Dry Storage System - Model 8800P

This diagram (left) illustrates the mechanical design of the 8800P dry storage sample cell system. The first position depicts the sensor immersed in the desiccant for dry storage. The sensor is separated from the desiccant by a very fine, stainless steel mesh with a thickness of approximately 5 mm. Close proximity of the sensor to the desiccant is crucial for fast dry down.

With the sensor in the dry storage position, the sample flows through the head space between the bottom of the sample cell and the sensor piston. In order to take a measurement, the gas outlet is temporarily blocked. The pressure of the sample flow pushes the piston and pulls the sensor into the sample cell where it wets up quickly to the moisture content in the sample flow. An accurate reading takes 1 to 2 minutes. Afterwards, the sensor is pushed back into dry storage by means of the sensor actuator which protrudes through the front of the instrument.

8800 Series Specifications

	8800A	8800B	8800T	8800P
Range by sensor type: XTR-100	-100 to 20°C (-148 to 68°F)			
XTR-65	-65 to 20°C (-85 to 68°F)			
Readouts	Dew point in °F and °C, ppmv, gH ₂ O / m ³ , lbs H ₂ O / mmscf			
Sensor type	High capacitance Al ₂ O ₃ (HTF)			
Accuracy	± 3°C (±5.5°F) or ±1% of the span			
Repeatability	± 0.5°C (±0.9°F)			
Capacitance	15 nF to 200 nF			
Sensor temp range	-30 to 50°C (22 to 122°F)			
Electronics temp range	-10 to 50°C (14 to 122°F)			
Response time	For a step change from -40 to -60°C • 63% in 90 seconds • 90% in 450 seconds			
Pressure operating range	Standard: 500 psi (34 Bar) Optional: 5000 psi (340 Bar)			Standard 28 psi (2 bar) Max: 100 psi (6.9 Bar)
Mechanical connection of sensor	14 mm x 1.25 mm threads, and 3/4" - 16 threads; flow cell with 1/4" tube fitting (option)			1/4" VCO input / output ports
Electrical connections	Female BNC connector	Female BNC connector	Female BNC connector	9 pin "D" for analog and RS-232
Intrinsically safe option	Class I & II, Div 1, Groups A through G and CENELEC, EexII A,B,C, T6 (when used with optional safety barriers)			
Display / indicator	Backlit LCD, 3.5 digits		3.5 digit LCD (no backlight)	Backlit LCD, 3.5 digits
Controls	4 push buttons		3 push buttons	4 push buttons
Power requirements	100 - 240 VAC, 50 or 60 Hz		24 VDC	9V battery
Output options	0/4 - 20 mA, RS-232		4-20 mA	0/4 - 20 mA, RS-232
Sensor cable	Coaxial cable (75Ω with capacitance of 50 pF/M) Maximum cable length = 3000 feet			N/A - sensor built in

 **TELEDYNE ANALYTICAL INSTRUMENTS**

A Teledyne Technologies Company
16830 Chestnut Street
City of Industry, California 91748, USA

TEL: 626-934-1500 or 888-789-8168
FAX: 626-934-1651 EMAIL: ask_tai@teledyne.com
www.teledyne-ai.com

© 2005 Teledyne Analytical Instruments, A Teledyne Technologies Company.
All rights reserved. Printed in the USA. 11/05LD

Warranty

Instrument is warranted for 1 year against defects in material or workmanship

NOTE: Specifications and features will vary with application. The above are established and validated during design, but are not to be construed as test criteria for every product. All specifications and features are subject to change without notice.

